



FALCON SHOCKS

JEEP WRANGLER JK MONOTUBE

QUICK START GUIDE

Correctly paired shocks are critical to a properly functioning suspension system. The relationship between spring and shock is inseparable.

By design, Falcon shocks provide extremely predictable handling by improving both compression and rebound. In-house engineering experts have invested hundreds of hours in dyno verified shock tuning to deliver optimal results that are literally felt by a 'seat-of-the-pants' experience. Falcon shocks are built with state of the art methods including CAD design, finite element analysis, in-house lab simulation and rigorous real world street and trail testing.



- Install tab, bushing, and flat bottom washer first



- Torque to 15 ft lb



- Ensure tab button is seated

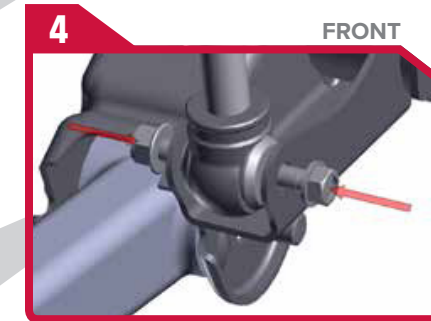

- Torque to 40 ft lb

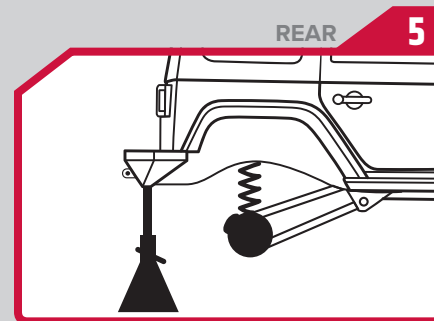

- With rear suspension at full droop remove rear tires (front optional), and existing shocks

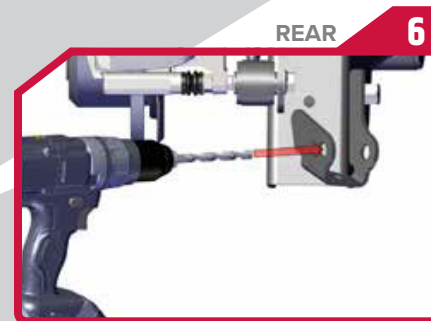

- Drill outside tab only using a 5/8" drill bit
Using the softest setting to make the adjustment easier

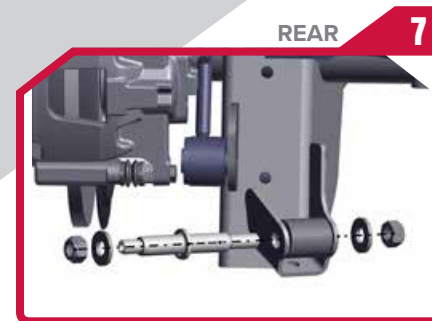

- Torque to 40 ft. lbs. Using 18mm. 6mm hex wrench will prevent bolt rotation

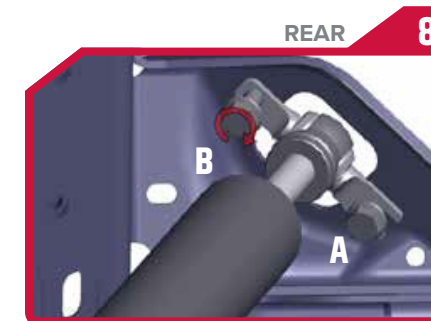

- A] Loosely install one bolt
- Slide on slotted end of bar pin
- B] Loosely install remaining bolt



- Grease will aid with installation



- Torque to 40 ft lb



- Torque both bolts to 30 ft lb

NOTES



RED LINE FULL SYNTHETIC OIL HAS A HIGH VISCOSITY INDEX OF 540 FOR SUPERIOR ALL-WEATHER PERFORMANCE.



HAND WASH WITH SOAP AND WATER FOR CLEANING. DO NOT CLEAN WITH ACIDS.



3 YEAR WARRANTY TO BE FREE OF DEFECTS AND WORKMANSHIP. REPAIR OR REPLACE AT NO COST.